

















# AUTO·MOW

## User Manual



# My Robot Home Compact

Screws :

(A)  Ø3.0*40 4+1 Pcs	(E)  Ø3.0*18 8+1 Pcs	(J)  10cm 2Pcs
(B)  M6*30 4 Pcs	(F)  Ø3.5*45 4+1 Pcs	(K)  5*5cm 2Pcs
(C)  Ø3.5*30 12+1 Pcs	(G)  2Pcs	(L)  2Pcs
(D)  Ø3.5*25 13+1Pcs	(H)  2 Pcs	(M)  Ø 3.0*10cm 5Pcs
	(I)  2 Pcs	(N)  2Pcs

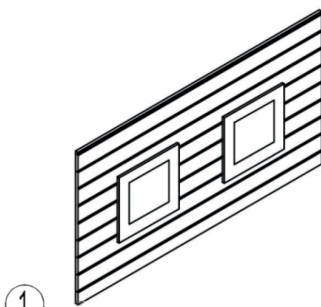

① Side panel x2 Pcs

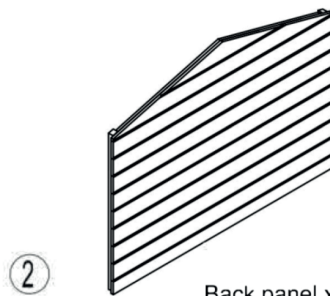

② Back panel x1 Pc

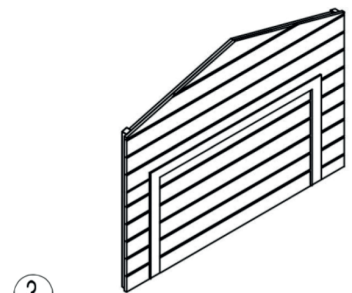

③ Front panel x1 Pc

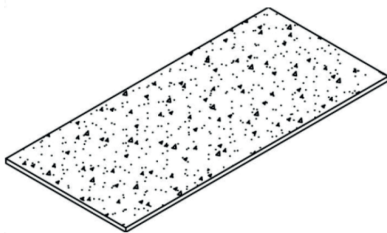

④ Roof x2 Pcs

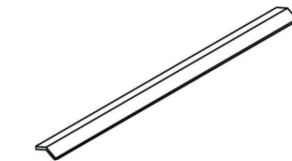

⑤ Roof cap x1 Pc

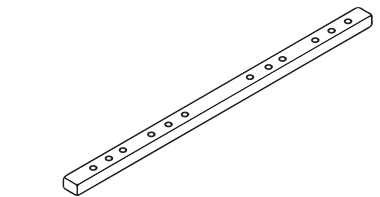

⑥ Wood bar x1 Pc



⑦ Wood side bar x2 Pcs

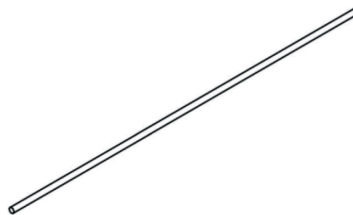

⑧ Metal bar x1 Pc



⑨ Metal side bar x2 Pcs



⑩ Metal middle bar x2 Pcs

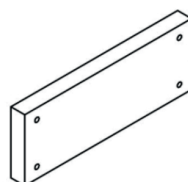

⑪ Counterweight iron plate x3 Pcs

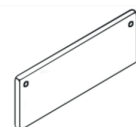

⑫ White PVC sign x1 Pcs



⑬ Small wood block x2 Pcs

**BEFORE STARTING THE INSTALLATION:**

1. For the best result, Auto-mow recommends placing the garage on concrete, brick, or similar flat and hard surface.
2. If installed on grass, Auto-Mow recommends that you put small bricks below on all 4 corners, to support the garage, and to make sure the garage will not sink into the ground.

**Step 1**

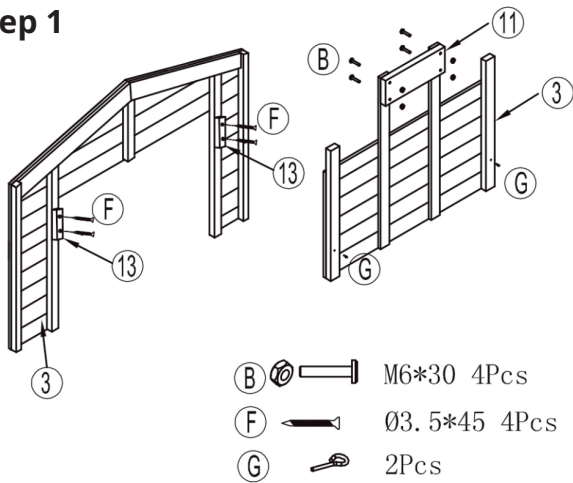

**Step 2**

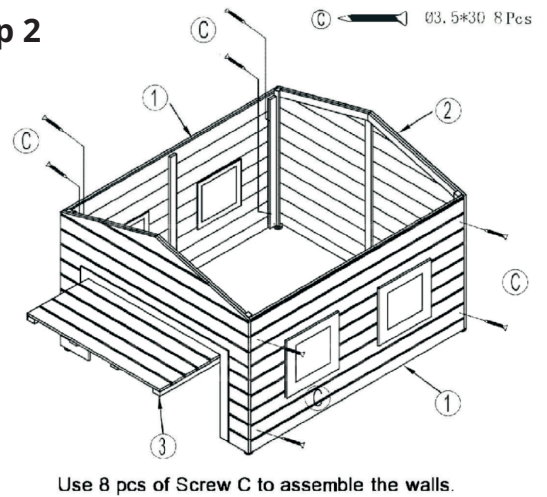

**Step 3**

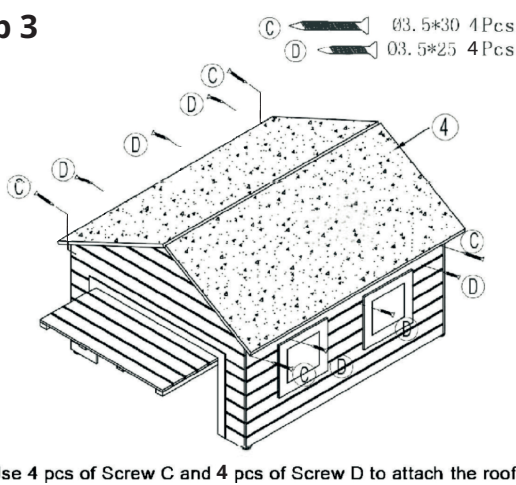

**Step 4**

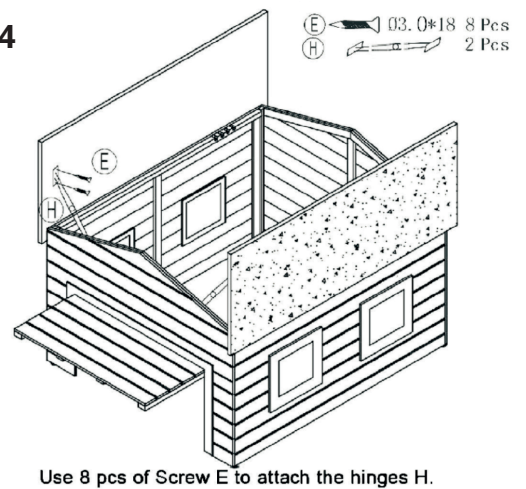

**Step 5**

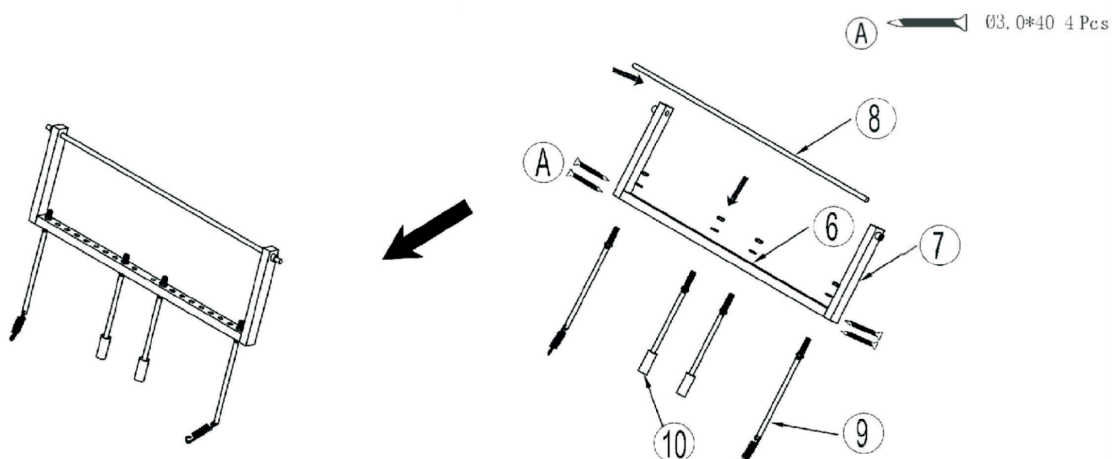

### Step 6

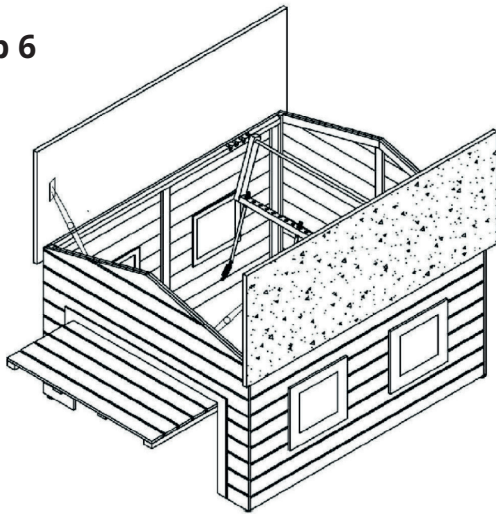

Place the docking station and the robot inside and adjust the door mechanism wire.  
Please go to page 4 and 5 for more guidance.

### Step 7

ⓓ ← 03.5\*25 3Pcs

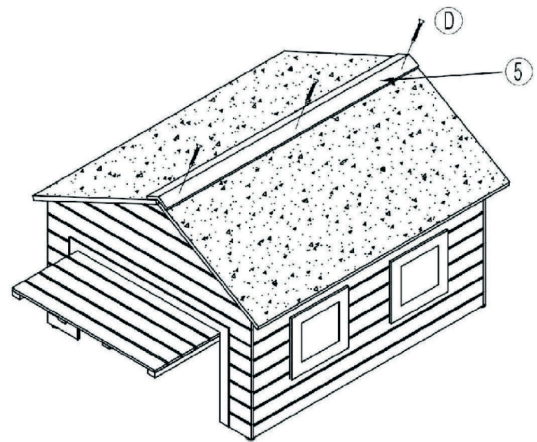

Use 3 pcs of screw D to attach the roof cap.

### Step 8

Ⓜ ← 03.0\*10cm 4Pcs  
Ⓝ ← 2Pcs

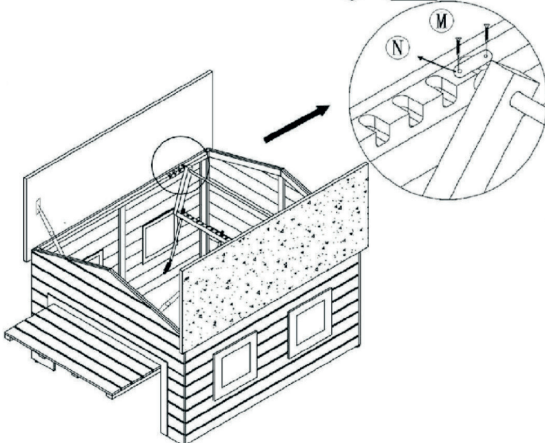

Apply once you have adjusted the mechanism to fit your robot mower size. Use 4 pcs of Screw M and 2 pcs of metal plates N to fix the mechanism.

### Step 9

Ⓛ ← 2Pcs

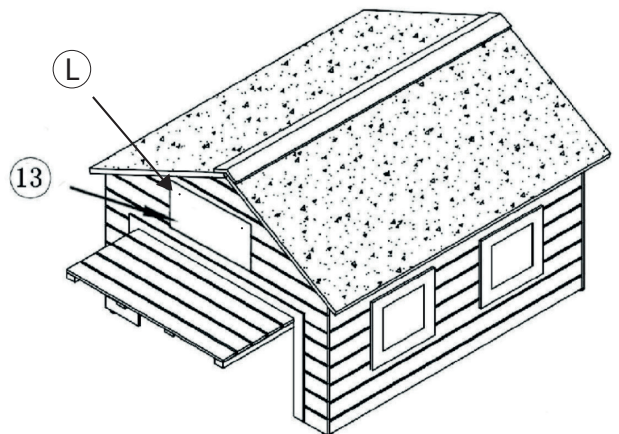

Use 2 pcs of screw L to add the White PVC Sign if desired.

### Step 10

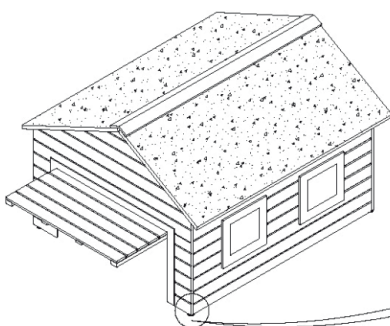

Adjust the level feet below the garage, so the port does not touch the ground/grass

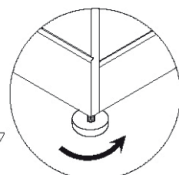

#### Remark:

We also have the Angle Bracket with long spikes. (Part J & Part K)  
If you want to fix the house to the ground, please use screw D to connect the Angle Bracket (K) to the house.  
Make sure the long spikes (J) are fixed in the ground.

# Auto-Mow - Adjustment of Garage Door Mechanism

## Step 1 - Insert Docking Station and Robot Mower

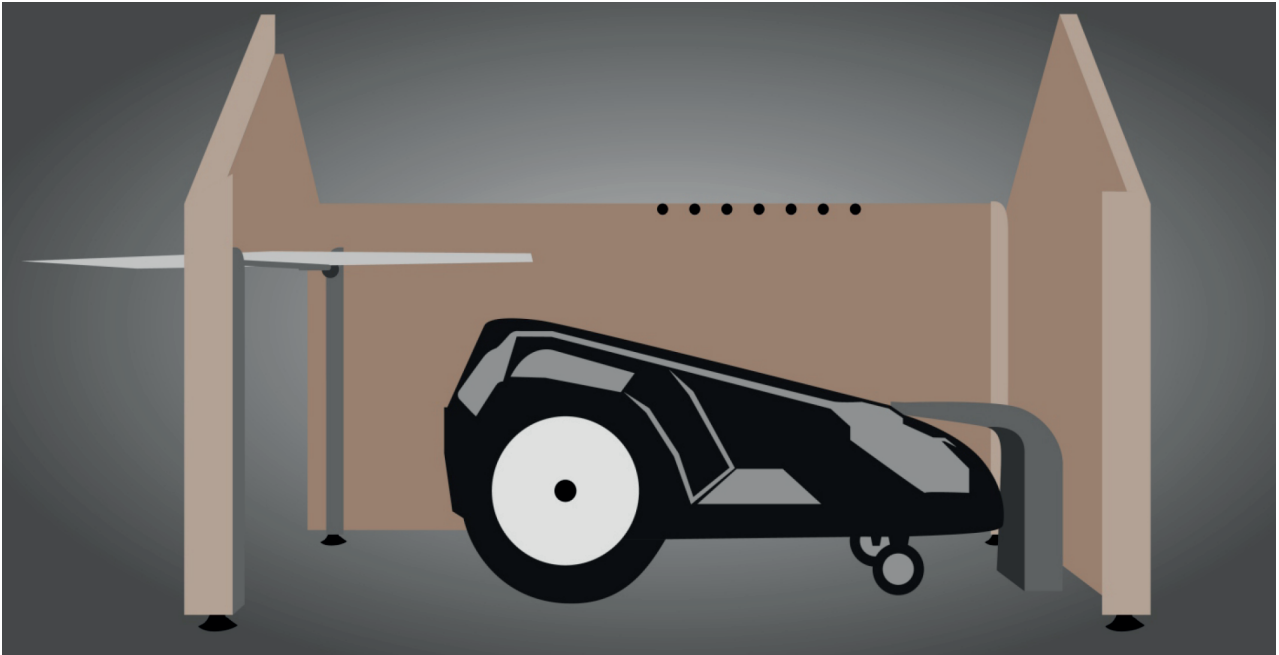

1. Place the docking station and robot mower in the center of the garage.

## Step 2 - Adjust mechanism to fit the Robot Mower and Docking Station

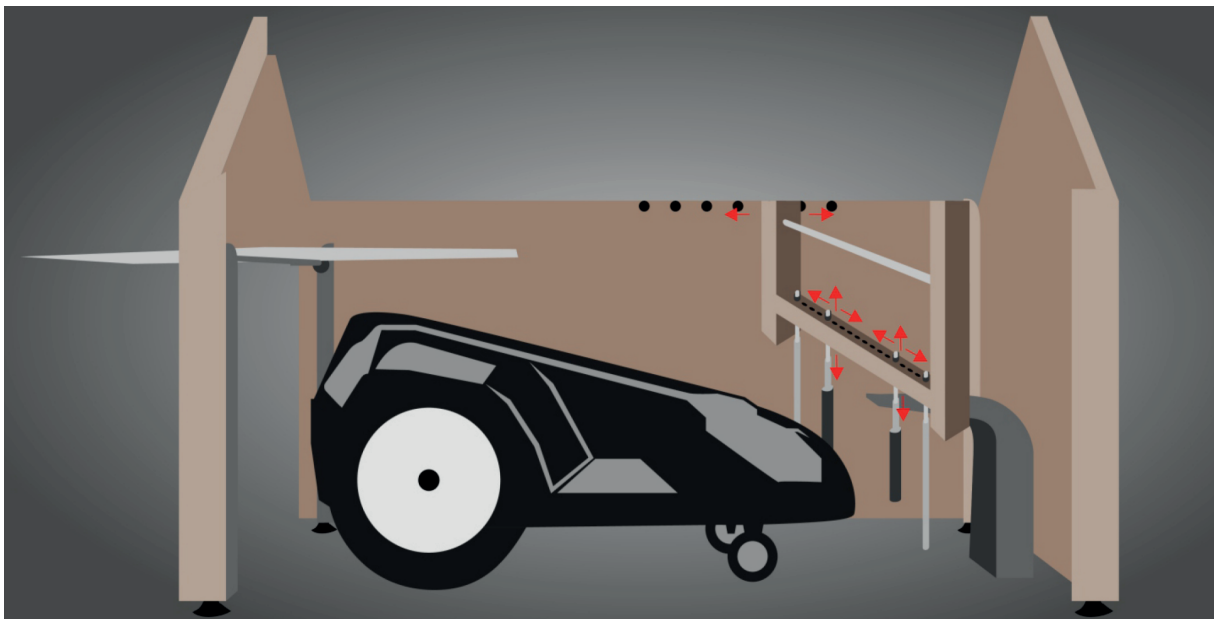

2. Fit the mechanism into the garage and adjust the 2 center poles, so it will match the robot size and docking station. At the top of the side panels you will be able to adjust the mechanism forward or backward. These adjustments will help you achieve a perfect fit for your robot mower.

### Step 3 - Remove Robot mower and lock the door

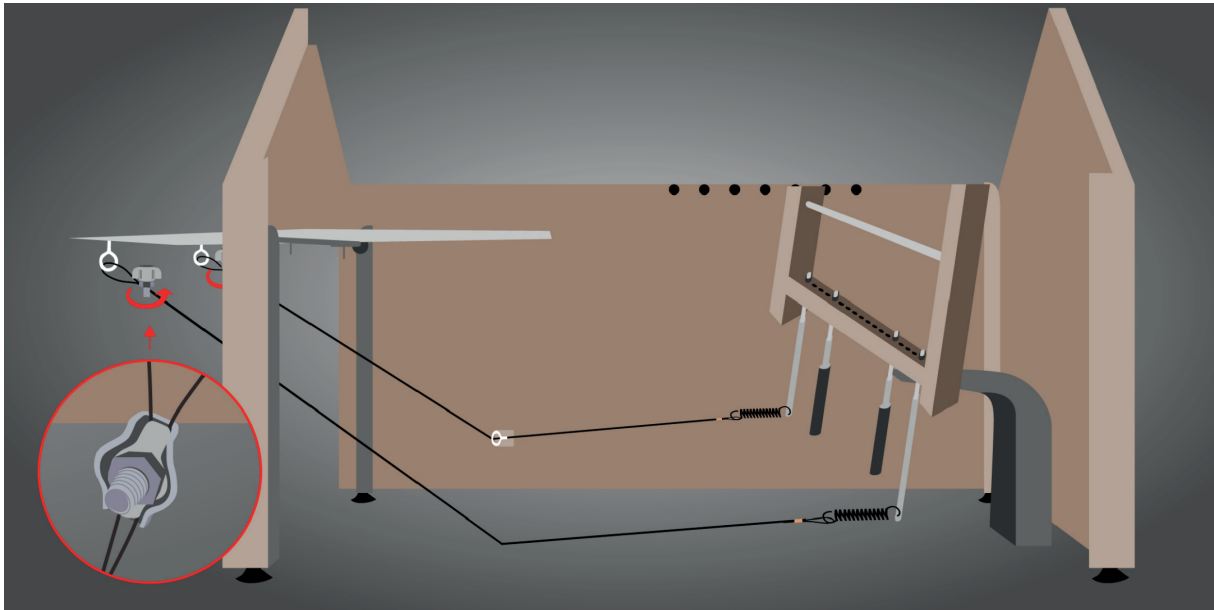

3. Open the door so it is horizontal and use the wire to connect the mechanism to the door. The mechanism must be in a forward position towards the door, as shown in the picture. Use the adjuster to tighten the wire to the door.

### Step 4 - Fit the wire length adjuster

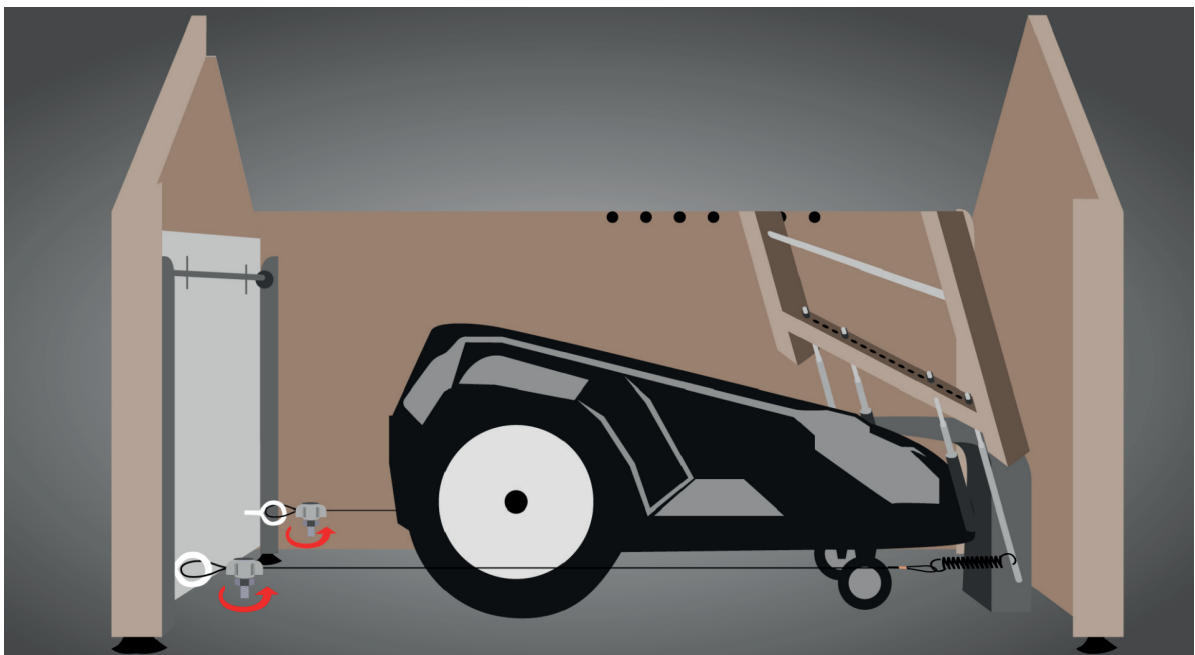

4. Test: Try to make the robot dock now, and if it is successful then the installation is done.

#### TROUBLESHOOTING:

- 1.If the door cannot open or close completely: Inspect the feet leveler beneath the garage.
- 2.If the door cannot close fully: Return to step 3 and fine-tune the mechanism's angle towards the door to provide a more extended push on the rods for complete closure.
- 3.If the door doesn't fully open: Return to step 3 and adjust the mechanism's angle towards the docking station.
- 4.If the door still struggles to open or lock: Go back to step 2 and readjust the mechanism at the top of the side panels for a optimal position.